

Rinnai

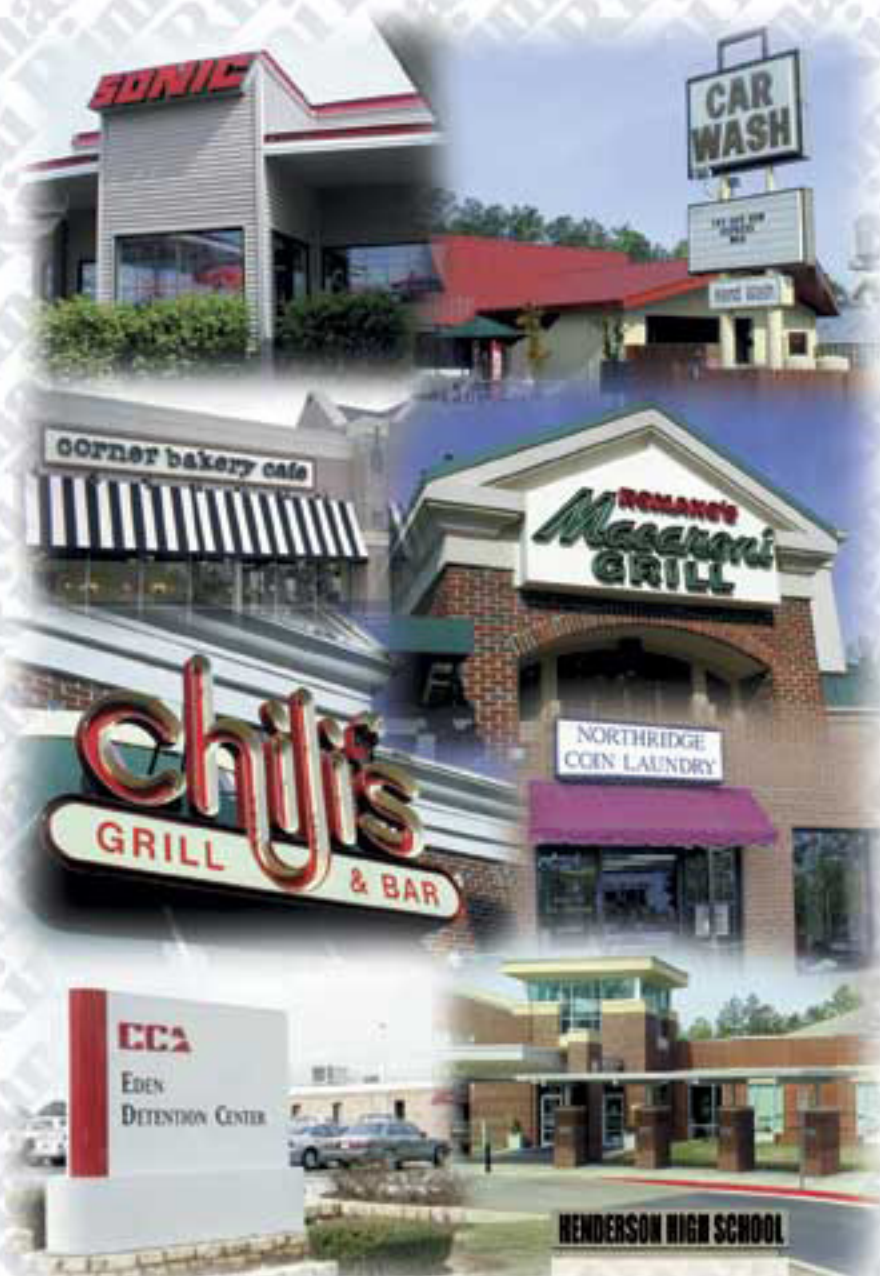

 **Continuum**[®]
Endless Hot Water System

Commercial Continuous Flow Water Heaters
Model 2424WC - External Commercial
Model 2532 FFU "C" - Internal Commercial



REMOTE CONTROLS

- Digital Display
- 96 - 180 Degree Settings
- Diagnostic Display



Model 2532 FFU "C" - Internal Commercial

FEATURES

- 15,000 to 180,000 BTUH Capacity
- .5 to 8.5 Gallons Per Minute Delivered Endlessly
- Uses Either Natural Gas Or Propane
- Internal Direct Vent Installation
- 8 3/4" Depth, 13 3/4" Width, 23 5/8" Height
- Easily Installed

CABINET

- Heavy Gauge, Textured, Gray Powder Coated Cabinet

VENTING

- Direct Vent Appliance - Uses No Indoor Air For Combustion

WARRANTY

- Exceptional 5-Year Warranty On The Heat Exchanger
- 5 Years On All Other Parts



Model 2424WC - External Commercial

FEATURES

- 19,000 to 180,000 BTUH Capacity
- .6 to 6.5 Gallons Per Minute Delivered Endlessly
- Uses Either Natural Gas Or Propane
- External Installation With No Indoor Combustion
- 6 3/4" Depth, 13 3/4" Width, 23 3/4" Height
- Easily Installed

CABINET

- Heavy Gauge, Textured, Gray Powder Coated Cabinet

VENTING

- External - No venting Required

WARRANTY

- Exceptional 5-Year Warranty On The Heat Exchanger
- 5 Years On All Other Parts

FLEXIBLE INSTALLATION ALLOWS YOU A CHOICE OF WHERE TO INSTALL

With Rinnai's internal Direct Vent Continuum you can choose where to install the unit, without concern for available combustion air inside your business. You can vent the Rinnai Continuum directly through the wall, or up through the roof. The air for combustion comes in the same vent that the burnt air exits!



EXTERNAL INSTALLATION GIVES YOU MORE ROOM INSIDE

In a fast food restaurant, maximizing your square footage is very important. Because Rinnai's Continuum Hot Water Heating System is outside, it frees up much needed space inside your restaurant. You could easily have another deep fryer or another spray sink. What could you do with the extra square footage?



NOTICEABLE SAVINGS ON YOUR GAS BILL

Using old technology water heaters or boilers means you have to heat water 24 hours a day whether you need it or not. With Rinnai's Continuum Hot Water Heating System, you heat water only when you use it, only the amount you use, and only to the temperature you need. Having hot water only when you use it will lower your gas bills every month!



NEVER ENDING HOT WATER

With old technology water tanks and boilers you can only set the temperature at the highest setting you'll need. Then, during peak hot water demands the water runs out and your employees have to wait to finish the task at hand. Having endless on demand hot water makes your restaurant run more efficiently!



CONTROLLABLE TEMPERATURE FROM 96 -180 DEGREES

Over heating water all the time costs you money. Why heat water to 160 degrees to mix in cold water to get the 140 degrees you need? Rinnai's exclusive "one touch" control panel let's you choose the right temperature you need.



Modulating 15,000 To 900,000 BUTH System
 .5GPM-32.5GPM At 50 Degree Rise

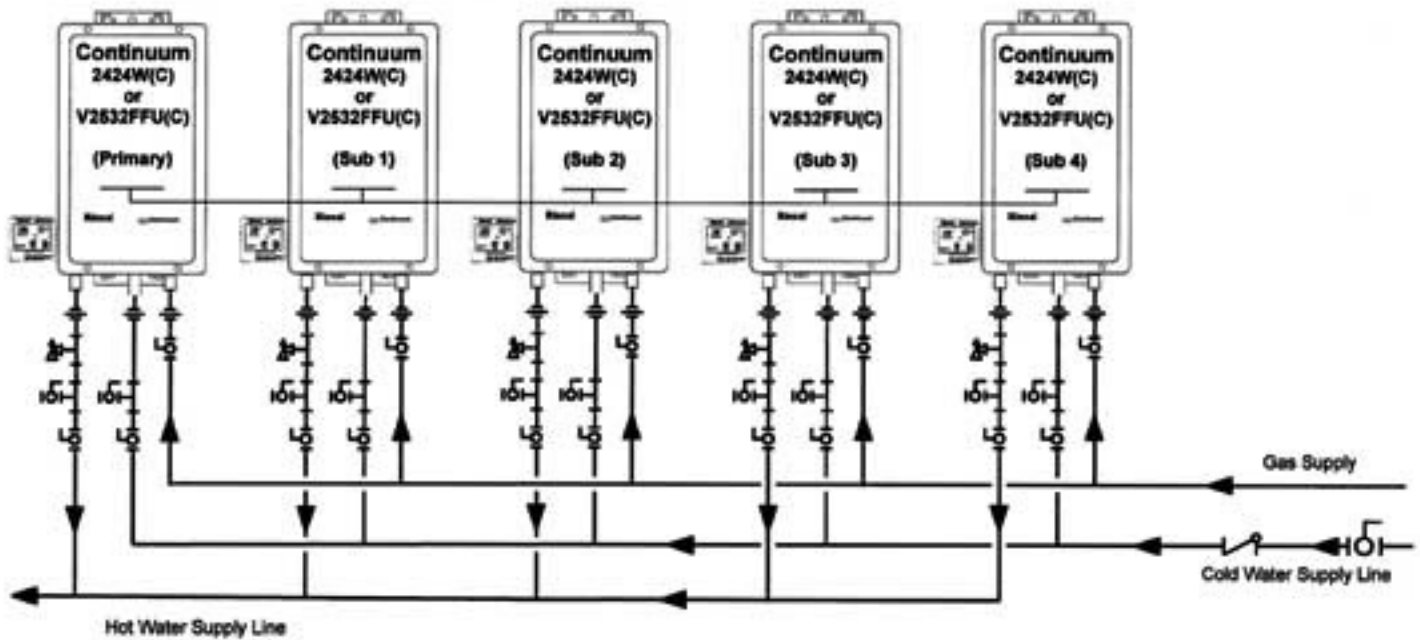

Modulating 15,000 To 900,000 BUTH System
 Unlimited Flow

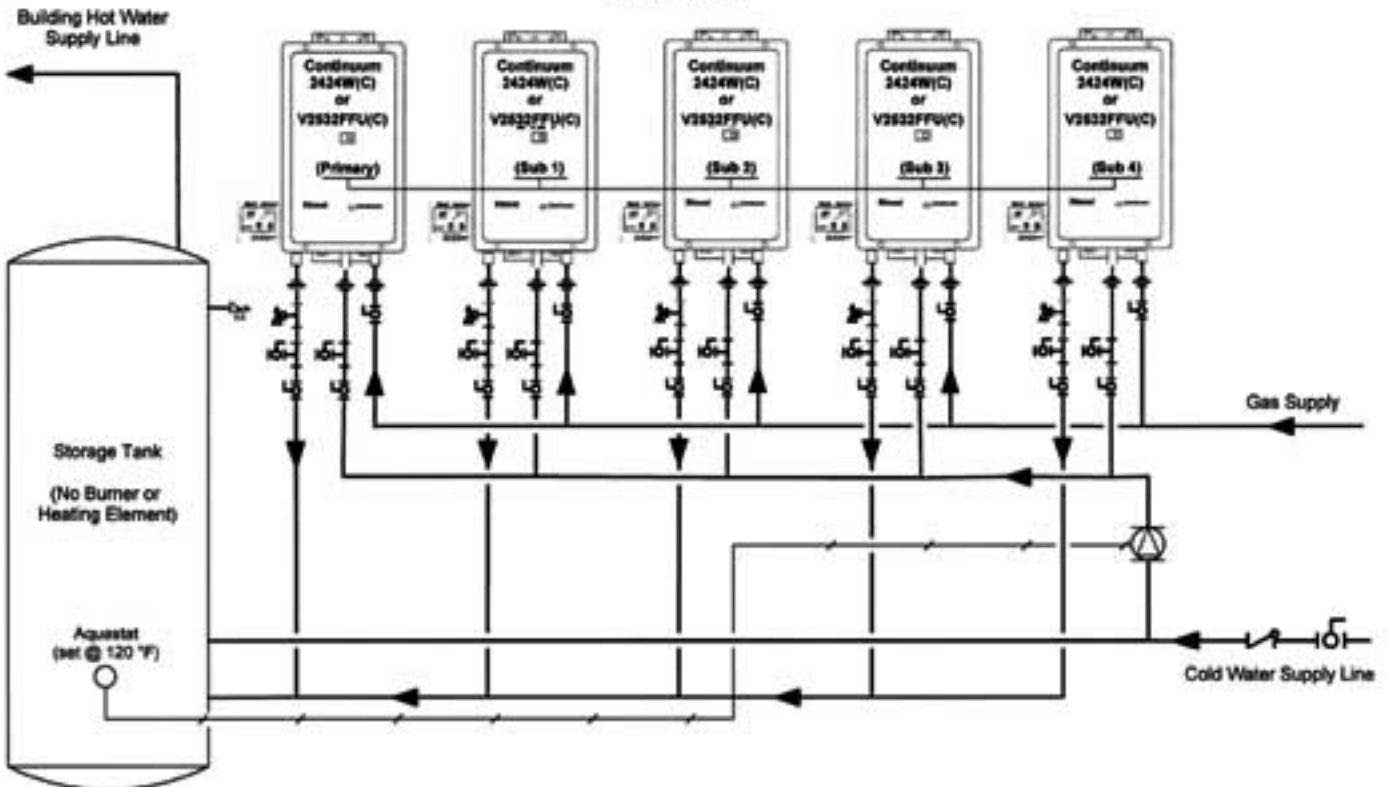

Rinnai  **Continuum**[®]
 Endless Hot Water System

*For more information or for a free demonstration
 contact us at 1.800.621.9419
 or visit our web site at www.rinnaina.com*